

Write your name here

Surname

Other names

Centre Number

Candidate Number

**Edexcel GCE**

**Physics**

**Advanced**

**Unit 4: Physics on the Move**

Thursday 27 January 2011 – Afternoon

**Time: 1 hour 35 minutes**

Paper Reference

**6PH04/01**

**You must have:**  
**Ruler**

Total Marks

### Instructions

- Use **black** ink or ball-point pen.
- **Fill in the boxes** at the top of this page with your name, centre number and candidate number.
- Answer **all** questions.
- Answer the questions in the spaces provided  
– *there may be more space than you need.*

### Information

- The total mark for this paper is 80.
- The marks for **each** question are shown in brackets  
– *use this as a guide as to how much time to spend on each question.*
- Questions labelled with an **asterisk** (\*) are ones where the quality of your written communication will be assessed  
– *you should take particular care with your spelling, punctuation and grammar, as well as the clarity of expression, on these questions.*
- The list of data, formulae and relationships is printed at the end of this booklet.
- Candidates may use a scientific calculator.

### Advice

- Read each question carefully before you start to answer it.
- Keep an eye on the time.
- Try to answer every question.
- Check your answers if you have time at the end.

Turn over ►

N37969A

©2011 Edexcel Limited.

1/1/1/1/1/



**edexcel**   
advancing learning, changing lives

## SECTION A

Answer ALL questions.

For questions 1–10, in Section A, select one answer from A to D and put a cross in the box . If you change your mind, put a line through the box  and then mark your new answer with a cross .

1 The area under a force-time graph represents

- A acceleration.
- B change in momentum.
- C displacement.
- D kinetic energy.

(Total for Question 1 = 1 mark)

2 A unit for flux linkage is the

- A tesla.
- B tesla per square metre.
- C weber.
- D weber per square metre.

(Total for Question 2 = 1 mark)

3 The electric field strength between two parallel plates is uniform. Which graph shows how the potential  $V$  varies with distance  $d$  from the positive plate?

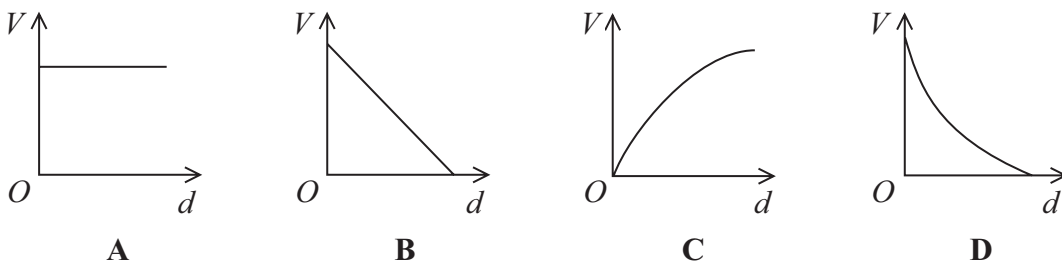

- A
- B
- C
- D

(Total for Question 3 = 1 mark)



4 The process by which electrons are released from a heated filament is known as

- A thermionic emission.
- B photoelectric emission.
- C ionisation.
- D excitation.

(Total for Question 4 = 1 mark)

5 A particle, mass 0.020 kg, is moving with an angular velocity of  $3\pi \text{ rad s}^{-1}$  around a circle of radius 0.50 m. The force, in N, responsible for this motion is

- A  $0.03\pi$  towards the centre of the circle.
- B  $0.03\pi$  away from the centre of the circle.
- C  $0.09\pi^2$  towards the centre of the circle.
- D  $0.09\pi^2$  away from the centre of the circle.

(Total for Question 5 = 1 mark)

6 The force on a proton at a point in an electric field is  $4.8 \times 10^{-19} \text{ N}$ .

The electric field strength at that point is

- A  $7.7 \times 10^{-38} \text{ N C}^{-1}$  in the opposite direction to the force.
- B  $7.7 \times 10^{-38} \text{ N C}^{-1}$  in the same direction as the force.
- C  $3.0 \times 10^{-19} \text{ N C}^{-1}$  in the opposite direction to the force.
- D  $3.0 \text{ N C}^{-1}$  in the same direction as the force.

(Total for Question 6 = 1 mark)

7 Which **one** of the following might **not** apply in interactions between sub atomic particles?

- A charge conservation
- B energy conservation
- C matter conservation
- D momentum conservation

(Total for Question 7 = 1 mark)



8 A pion could consist of

- A  $u\bar{d}$
- B  $ud$
- C  $uud$
- D  $uud\bar{d}$

(Total for Question 8 = 1 mark)

9 Data at the back of the examination paper can be used with the formula  $\Delta E = c^2 \Delta m$  to calculate

- A the amount of energy in a proton.
- B the mass of coal that produces 6 MJ of energy when burnt.
- C the energy produced when an electron and a positron annihilate.
- D the energy produced when two protons collide.

(Total for Question 9 = 1 mark)

10 A particle X has kinetic energy  $E$  and momentum  $p$ . Another particle Y of the same mass as X has a momentum  $2p$ . The kinetic energy of Y is

- A  $\frac{1}{2}E$
- B  $E$
- C  $2E$
- D  $4E$

(Total for Question 10 = 1 mark)

**TOTAL FOR SECTION A = 10 MARKS**



**SECTION B**

**Answer ALL questions in the spaces provided.**

**11** A particle called a B meson has been observed to decay into an antiproton plus a lambda ( $\Lambda$ ) particle. The lambda particle consisted of an up, a down and a charmed quark.

The following table summarises the charges on these quarks.

Quark	Charge / $e$
Up (u)	$+\frac{2}{3}$
Down (d)	$-\frac{1}{3}$
Charm (c)	$+\frac{2}{3}$

(a) Circle the correct word from the list below to describe the lambda particle. (1)

Baryon      Lepton      Meson      Anti-particle

(b) Calculate the charge on the lambda particle. (1)

.....  
.....

Charge = .....

(c) Write an equation using standard particle symbols for this decay. (2)

.....  
.....  
.....

**(Total for Question 11 = 4 marks)**



**BLANK PAGE**



\*12 The photograph shows tracks produced by charged particles in a bubble chamber.

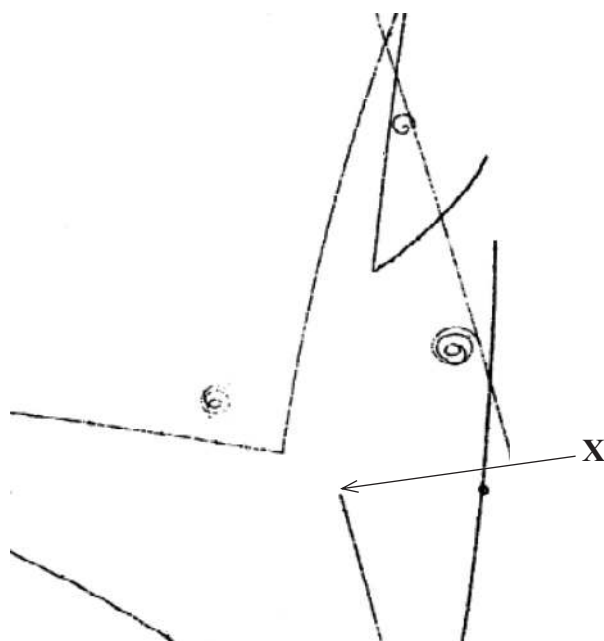

At X, an incoming charged particle interacts with a stationary proton to produce a neutral lambda particle and a neutral kaon particle. Both these particles later decay into other particles.

With reference to the photograph, describe and explain the evidence provided for this event.

(4)

.....

.....

.....

.....

.....

.....

.....

.....

.....

.....

.....

(Total for Question 12 = 4 marks)



13 The simplified diagram shows a d.c. electric motor. The split ring commutator consists of two copper semicircular sections attached to either end of a coil. Fixed carbon brushes rub against, and make electrical connections to, the split ring commutator.

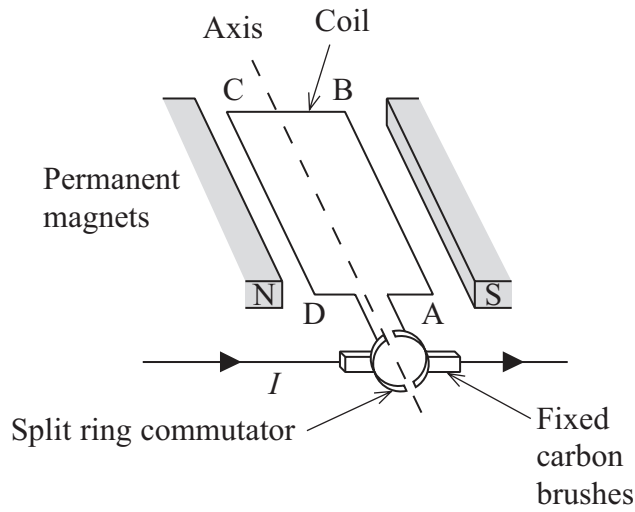

(a) Explain why the coil turns and why it continues to rotate. Add to the diagram to help your explanation.

(4)

.....

.....

.....

.....

.....

.....

.....

.....

.....

.....





\*(b) When the motor is first switched on the current  $I$  is large. As the coil turns faster, the current decreases.

Explain these observations.

(4)

.....

.....

.....

.....

.....

.....

.....

.....

.....

.....

.....

**(Total for Question 13 = 8 marks)**



14 Muons have the same charge as electrons and can be produced by particle experiments. Muons belong to a family of fundamental particles called leptons. Muons have a short life and decay to electrons. Exotic atoms can be produced in which muons have been substituted for electrons. For example, muonic hydrogen consists of a proton and a muon.

(a) What is meant by a fundamental particle?

(1)

(b) Sketch the electric field around a muon.

(3)

(c) The mass of a muon is  $106 \text{ MeV}/c^2$ . Show that its mass is about 200 times that of an electron.

(3)



(d) Calculate the electric force between the muon and proton in the muonic hydrogen atom.

distance between muon and proton =  $2.7 \times 10^{-13}$  m

(2)

.....

.....

.....

.....

.....

Electric force = .....

(e) Emission line spectra in the X-ray region of the electromagnetic spectrum can be detected from muonic hydrogen atoms.

Outline the atomic processes that produce emission spectra and suggest why they are X-rays in this case.

(3)

.....

.....

.....

.....

.....

.....

.....

.....

.....

.....

**(Total for Question 14 = 12 marks)**



15 A student sets up the circuit shown in the diagram.

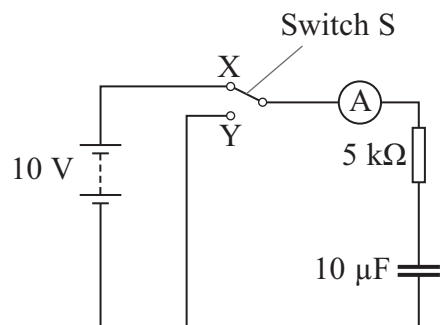

(a) (i) She moves switch S from X to Y. Explain what happens to the capacitor.

(2)

(ii) On the axis below, sketch a graph to show how the current in the ammeter varies with time from the moment the switch touches Y. Indicate typical values of current and time on the axes of your graph.

(3)

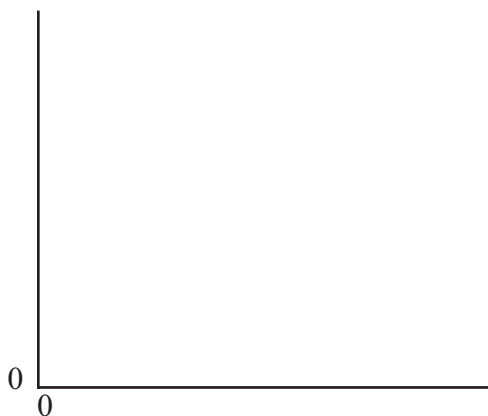

(iii) Describe how the graph would appear when the switch is moved back to X. (2)

.....

.....

.....

(b) Calculate the maximum energy stored on the capacitor in this circuit. (2)

.....

.....

.....

Maximum energy = .....

(c) The student wants to use this circuit to produce a short time delay, equal to the time it takes for the potential difference across the capacitor to fall to 0.07 of its maximum value.

Calculate this time delay. (2)

.....

.....

.....

.....

.....

Time delay = .....

**(Total for Question 15 = 11 marks)**



16 (a) Describe the key observations of the alpha particle scattering experiments which led to Rutherford's nuclear model of the atom.

(3)

.....

.....

.....

.....

.....

.....

.....

.....

(b) Experiments at Stanford University's linear accelerator (linac) accelerate electrons up to energies of 20 GeV.

(i) State the main features of a linac.

(3)

.....

.....

.....

.....

.....



(ii) Calculate the de Broglie wavelength of 20 GeV electrons. At these energies, the following relativistic equation applies  $E = pc$ .

(3)

.....

.....

.....

De Broglie wavelength = .....

(iii) Suggest why these electrons would be particularly useful for investigating nuclear structure.

(1)

.....

.....

.....

(iv) These electrons can be aimed at a hydrogen target. Some of these electrons are scattered at large angles by the protons whilst others pass straight through.

Suggest what this tells you about the structure of a proton.

(2)

.....

.....

.....

(v) The scattering process is inelastic. What is meant by an inelastic collision?

(1)

.....

.....

.....

**(Total for Question 16 = 13 marks)**



17 (a) A cyclotron can be used to accelerate charged particles.

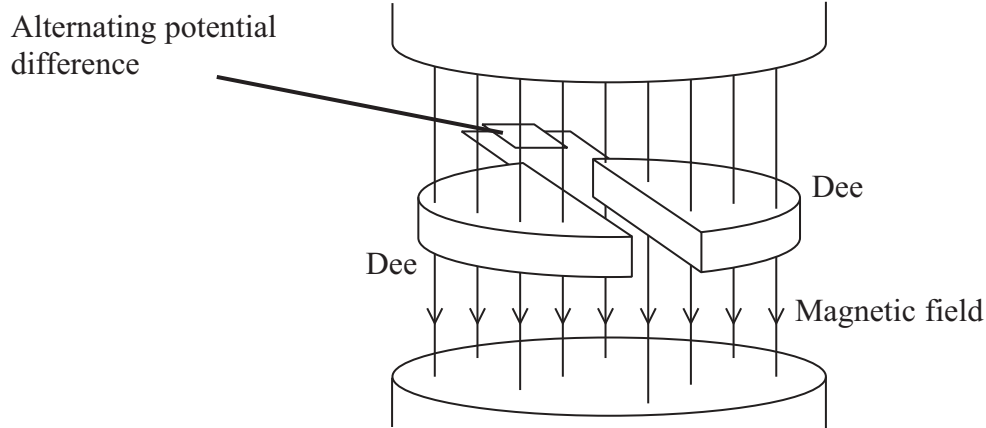

Explain the purpose of the magnetic field in a cyclotron. You may add to the diagram if you wish.

(2)

.....

.....

.....

(b) A beam of low-speed protons are introduced into a cyclotron.

(i) Show that the number of revolutions per second,  $f$ , completed by the protons is given by

$$f = \frac{eB}{2\pi m}$$

where  $e$  is the electronic charge  
 $B$  is the uniform magnetic flux density within the cyclotron  
 $m$  is the mass of the proton.

(3)

.....

.....

.....

.....

.....

.....

.....





(ii) An alternating potential difference is placed across the two dees to increase the energy of the protons.

Explain why the potential difference that is used is alternating.

(2)

.....

.....

.....

.....

(iii) Initially, whilst the proton speeds are low, the frequency at which the potential difference has to alternate is constant.

Explain how the frequency must change as the protons gain more and more energy.

(2)

.....

.....

.....

.....

(c) In the Large Hadron Collider at CERN, protons follow a circular path with speeds close to the speed of light. X-rays can be produced by free protons which are accelerating.

Explain why this provides a source of X-rays even though the speeds of the protons are constant.

(2)

.....

.....

.....

.....

**(Total for Question 17 = 11 marks)**



18 A student is using a 'Newton's Cradle'. This consists of a set of identical solid metal balls hanging by threads from a frame so that they are in contact with each other.

She initially pulls one ball to the side as shown.

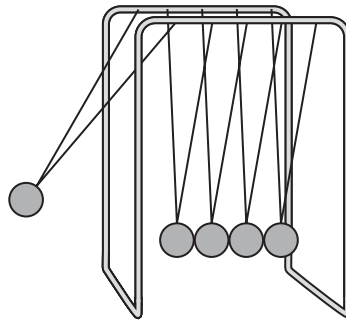

She releases the ball, it collides with the nearest stationary ball and stops. The ball furthest to the right immediately moves away. The middle three balls remain stationary.

\*(a) Explain what measurements the student would take and describe how she would use them to investigate whether momentum had been conserved in this event.

(4)

.....

.....

.....

.....

.....

.....

.....

.....

.....

.....

.....

.....

.....

.....

.....

.....

.....

.....

.....

.....

.....

.....



(b) The student makes the following observations:

- the ball on the right returns and collides with a similar result; this repeats itself a number of times
- after a while, the middle balls are also moving
- shortly afterwards, the balls all come to rest.

Discuss these observations in terms of energy.

(3)

.....

.....

.....

.....

.....

.....

.....

.....

.....

.....

---

**(Total for Question 18 = 7 marks)**

---

**TOTAL FOR SECTION B = 70 MARKS**

**TOTAL FOR PAPER = 80 MARKS**



## List of data, formulae and relationships

Acceleration of free fall	$g = 9.81 \text{ m s}^{-2}$	(close to Earth's surface)
Boltzmann constant	$k = 1.38 \times 10^{-23} \text{ J K}^{-1}$	
Coulomb's law constant	$k = 1/4\pi\epsilon_0$ $= 8.99 \times 10^9 \text{ N m}^2 \text{ C}^{-2}$	
Electron charge	$e = -1.60 \times 10^{-19} \text{ C}$	
Electron mass	$m_e = 9.11 \times 10^{-31} \text{ kg}$	
Electronvolt	$1 \text{ eV} = 1.60 \times 10^{-19} \text{ J}$	
Gravitational constant	$G = 6.67 \times 10^{-11} \text{ N m}^2 \text{ kg}^{-2}$	
Gravitational field strength	$g = 9.81 \text{ N kg}^{-1}$	(close to Earth's surface)
Permittivity of free space	$\epsilon_0 = 8.85 \times 10^{-12} \text{ F m}^{-1}$	
Planck constant	$h = 6.63 \times 10^{-34} \text{ J s}$	
Proton mass	$m_p = 1.67 \times 10^{-27} \text{ kg}$	
Speed of light in a vacuum	$c = 3.00 \times 10^8 \text{ m s}^{-1}$	
Stefan-Boltzmann constant	$\sigma = 5.67 \times 10^{-8} \text{ W m}^{-2} \text{ K}^{-4}$	
Unified atomic mass unit	$u = 1.66 \times 10^{-27} \text{ kg}$	

### Unit 1

#### Mechanics

Kinematic equations of motion	$v = u + at$ $s = ut + \frac{1}{2}at^2$ $v^2 = u^2 + 2as$
Forces	$\Sigma F = ma$ $g = F/m$ $W = mg$
Work and energy	$\Delta W = F\Delta s$ $E_k = \frac{1}{2}mv^2$ $\Delta E_{\text{grav}} = mg\Delta h$

#### Materials

Stokes' law	$F = 6\pi\eta rv$
Hooke's law	$F = k\Delta x$
Density	$\rho = m/V$
Pressure	$p = F/A$
Young's modulus	$E = \sigma/\epsilon$ where Stress $\sigma = F/A$ Strain $\epsilon = \Delta x/x$
Elastic strain energy	$E_{\text{el}} = \frac{1}{2}F\Delta x$



## Unit 2

### Waves

Wave speed	$v = f\lambda$
Refractive index	${}_1\mu_2 = \sin i / \sin r = v_1/v_2$

### Electricity

Potential difference	$V = W/Q$
----------------------	-----------

Resistance	$R = V/I$
------------	-----------

Electrical power, energy and efficiency	$P = VI$
	$P = I^2R$
	$P = V^2/R$
	$W = VI t$

$$\% \text{ efficiency} = \frac{\text{useful energy output}}{\text{energy input}} \times 100$$

$$\% \text{ efficiency} = \frac{\text{useful power output}}{\text{power input}} \times 100$$

Resistivity	$R = \rho l/A$
-------------	----------------

Current	$I = \Delta Q/\Delta t$
	$I = nqvA$

Resistors in series	$R = R_1 + R_2 + R_3$
---------------------	-----------------------

Resistors in parallel	$\frac{1}{R} = \frac{1}{R_1} + \frac{1}{R_2} + \frac{1}{R_3}$
-----------------------	---

### Quantum physics

Photon model	$E = hf$
--------------	----------

Einstein's photoelectric equation	$hf = \phi + \frac{1}{2}mv_{\max}^2$
-----------------------------------	--------------------------------------



## Unit 4

### Mechanics

Momentum	$p = mv$
Kinetic energy of a non-relativistic particle	$E_k = p^2/2m$
Motion in a circle	$v = \omega r$ $T = 2\pi/\omega$ $F = ma = mv^2/r$ $a = v^2/r$ $a = r\omega^2$

### Fields

Coulomb's law	$F = kQ_1Q_2/r^2$ where $k = 1/4\pi\epsilon_0$
Electric field	$E = F/Q$ $E = kQ/r^2$ $E = V/d$
Capacitance	$C = Q/V$
Energy stored in capacitor	$W = \frac{1}{2}QV$
Capacitor discharge	$Q = Q_0e^{-t/RC}$
In a magnetic field	$F = BIl \sin \theta$ $F = Bqv \sin \theta$ $r = p/BQ$
Faraday's and Lenz's Laws	$\epsilon = -d(N\phi)/dt$

### Particle physics

Mass-energy	$\Delta E = c^2 \Delta m$
de Broglie wavelength	$\lambda = h/p$



**BLANK PAGE**



**BLANK PAGE**

